

B102024.03828

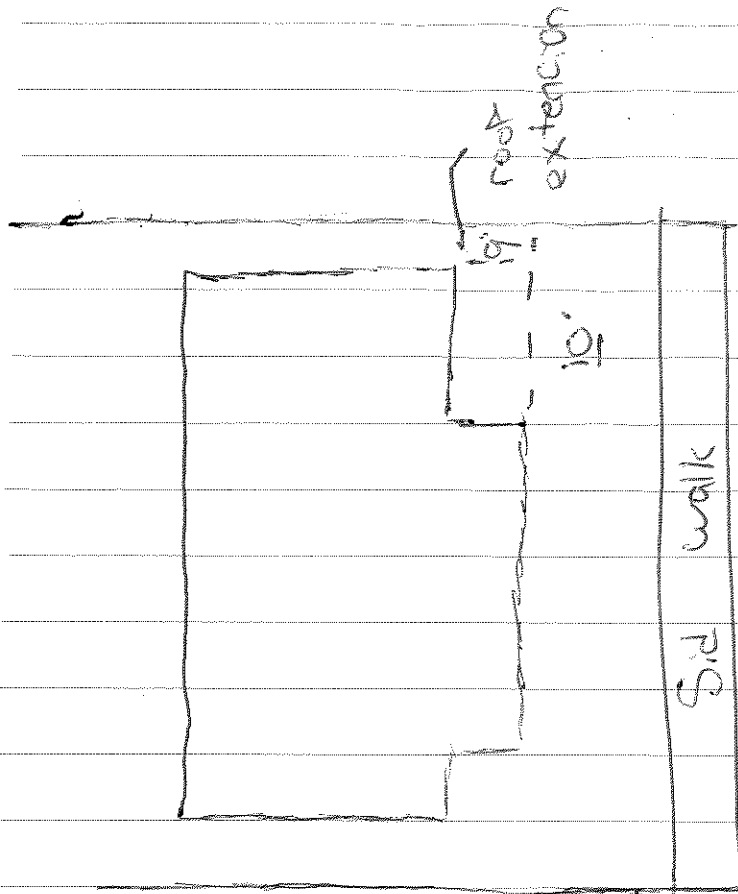

126 Maynell Ave
Madesto OR



ATTACHED OPEN PATIO

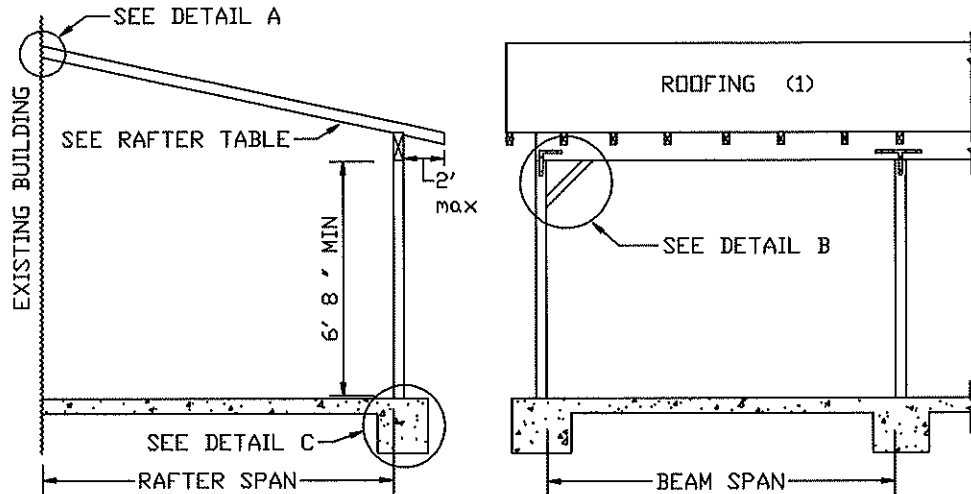

* The following table is based upon Doug. Fir #2 or better.
 * This table of allowable spans (based upon 10 psf DL) is for comp. or wood shake/ shingles only. No tile allowed.

Rafter Spans			Beam Spans	
Size	Spacing	Horizontal Projection	Size	Horizontal Projection
2 X 4	12'	10'10"	4 X 4	4'0"
	16'	9'10"	4 X 6	6'0"
	24'	8'0"	4 X 8	8'0"
2 X 6	12'	16'7"	4 X 10	9'9"
	16'	14'4"	4 X 12	11'5"
	24'	11'9"	Beam spans based on 2 X 8 rafters at 12' c/c with 2' max. overhang	
2 X 8	12'	21'0"		
	16'	18'2"		
	24'	14'10"		

NOTES

FOR CONSTRUCTION NOT CONSISTENT WITH THE FRAMING METHODS SHOWN ABOVE, APPROVAL MUST BE OBTAINED FROM THE BUILDING SAFETY DIVISION OFFICE PRIOR TO STARTING ANY WORK.

1. Roof covering shall be placed in accordance with CBC Sec. 1507 and the manufacturer's installation instructions.
2. 2X ledger may be placed over stucco. Lag screw (lag bolt) fasteners must be a minimum of 1/2" diameter and a minimum of 5' in length. Embedment into existing support framing must be 4 diameters with a minimum 2 1/4" embedment. Predrilling holes for lag screw installation is required. Fasteners may be spaced according to the wall studs but in no case more than 24" c/c.
3. Provide on plot plan all existing buildings with dimensions to lot lines and between buildings.

DETAIL A

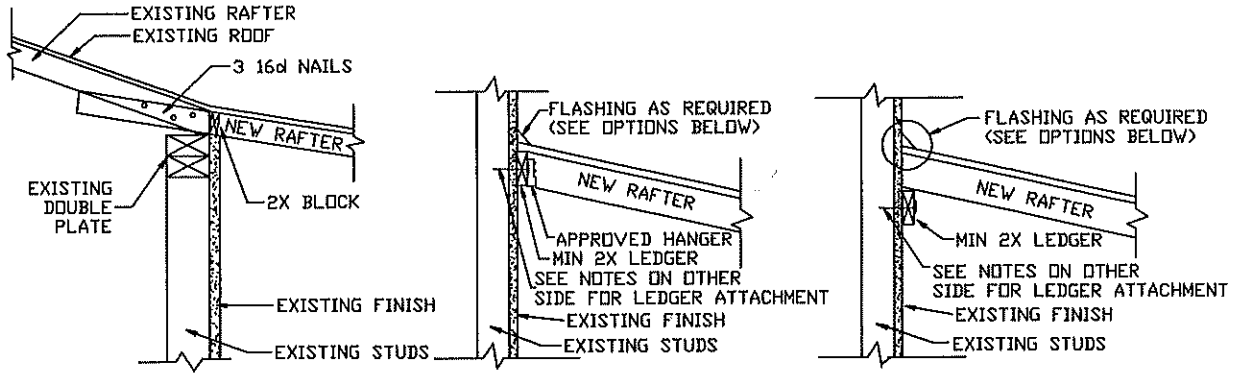

DETAIL B

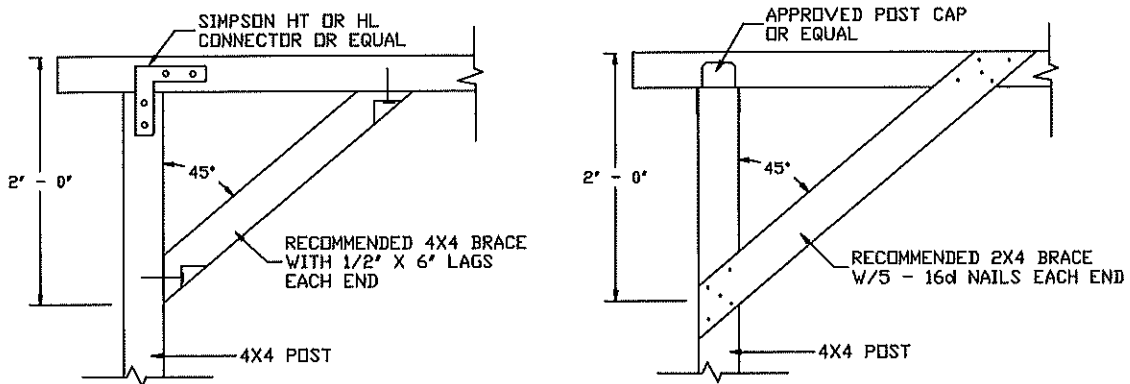

DETAIL C

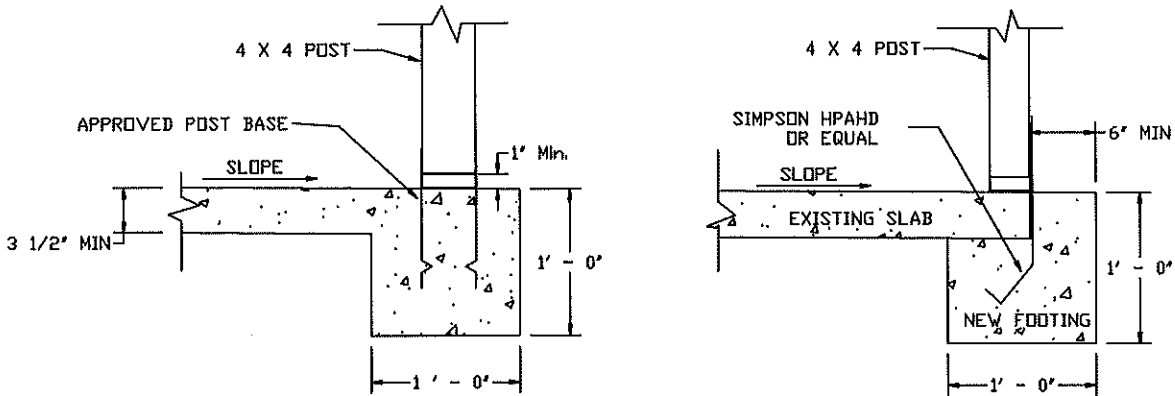

FLASHING (ENLARGED FOR CLARITY)

